

Penstock Ø400-Ø900

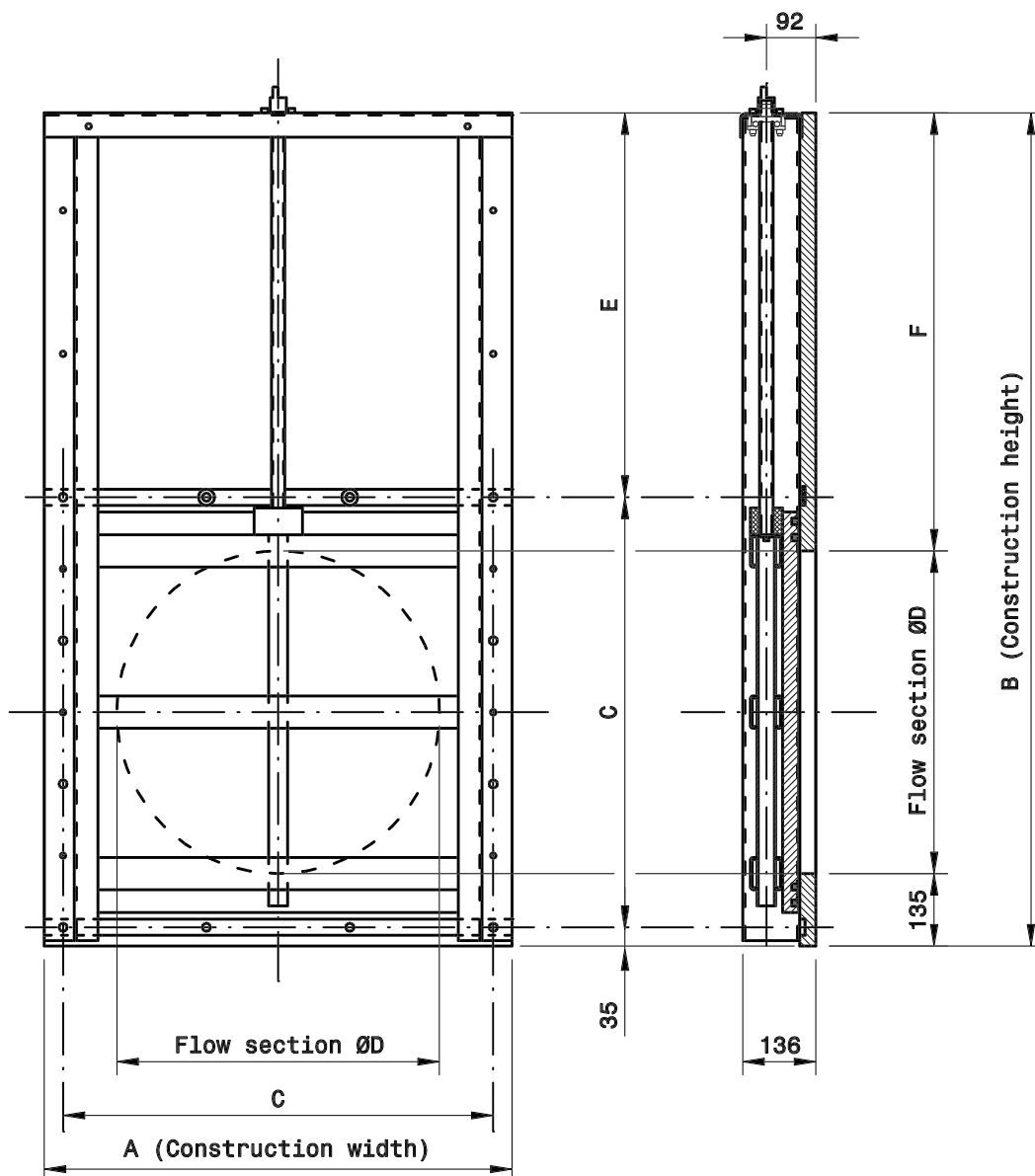

ØD	A	B	C	E	F	Mounting (M12)	Weight
400	670	1150	600 (3x 200)	515	615	10x Anchor + 2x CS	55 kg
500	770	1350	700 (3x 233)	615	715	10x Anchor + 2x CS	75 kg
600	870	1550	800 (3x 267)	715	815	10x Anchor + 2x CS	90 kg
700	970	1750	900 (3x 300)	815	915	10x Anchor + 2x CS	110 kg
800	1070	1950	1000 (5x 200)	915	1015	16x Anchor + 4x CS	130 kg
900	1170	2150	1100 (5x 220)	1015	1115	16x Anchor + 4x CS	155 kg

Material specification

Slide and seat	- HDPE-300	Spindle bearing	- Stainless steel ball bearing
Spindle TR25x7.5L.	- Stainless AISI316	Sealing	- EPDM
Frame and tubes	- Stainless AISI316	Bolts and nuts	- A4
Threaded lift block	- POM		

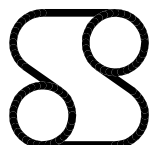

Synthesis BV - tel. +31 (0)321 380457
Koperweg 17 - 8251 KA Dronten

Detail penstock Ø400-Ø900

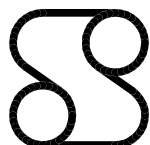
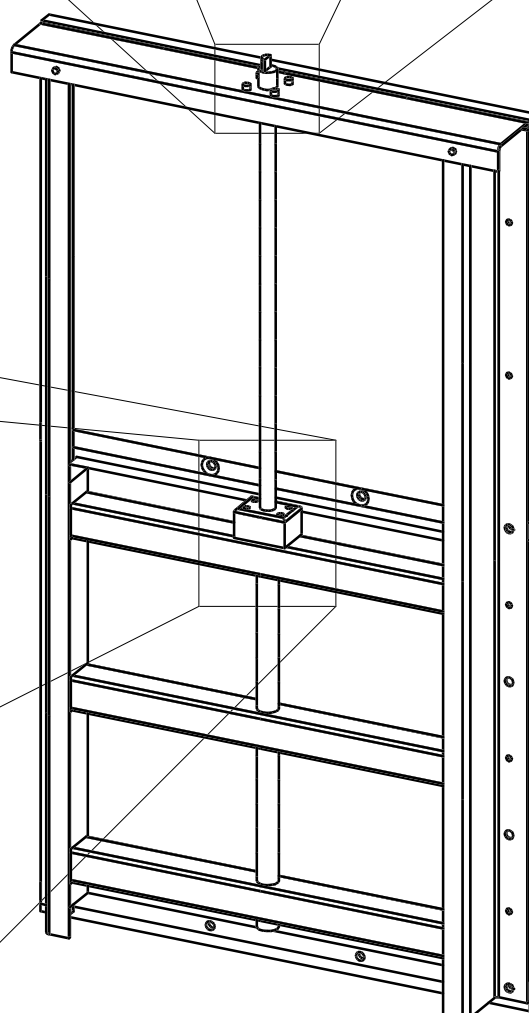
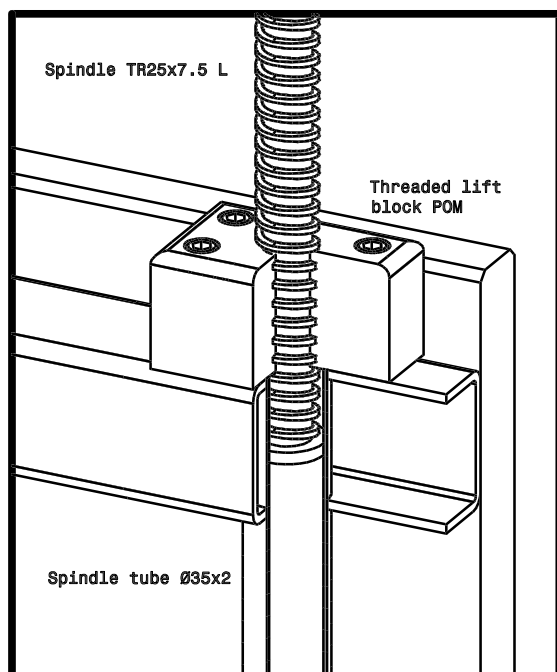
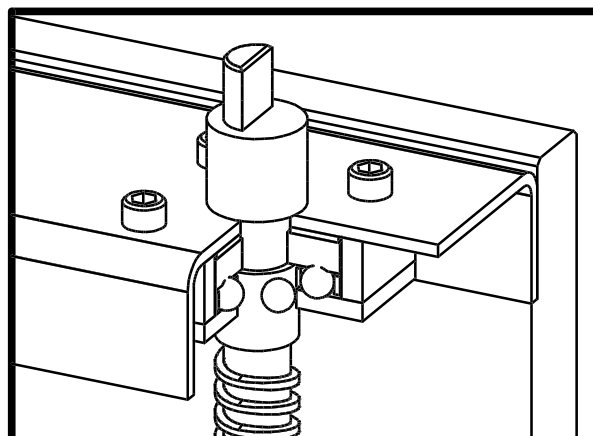
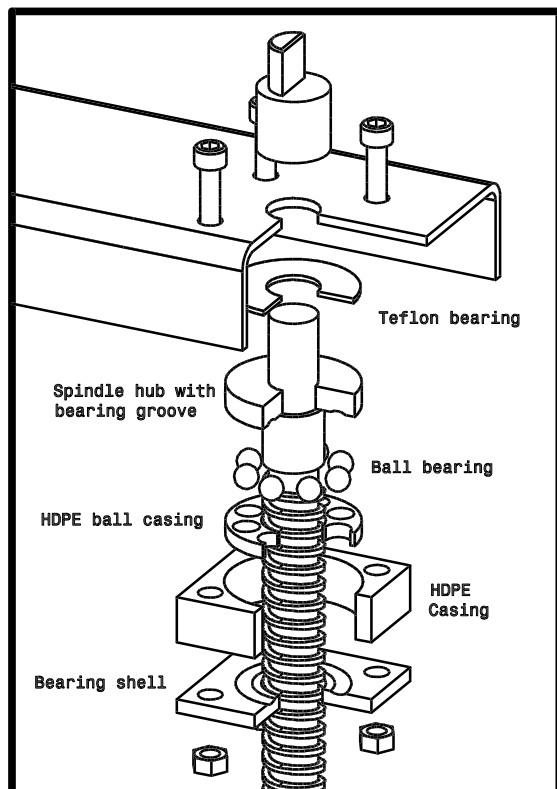

Synthesis BV - tel. +31 (0)321 380457
Koperweg 17 - 8251 KA Dronten

Detail penstock Ø400-Ø900

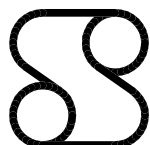
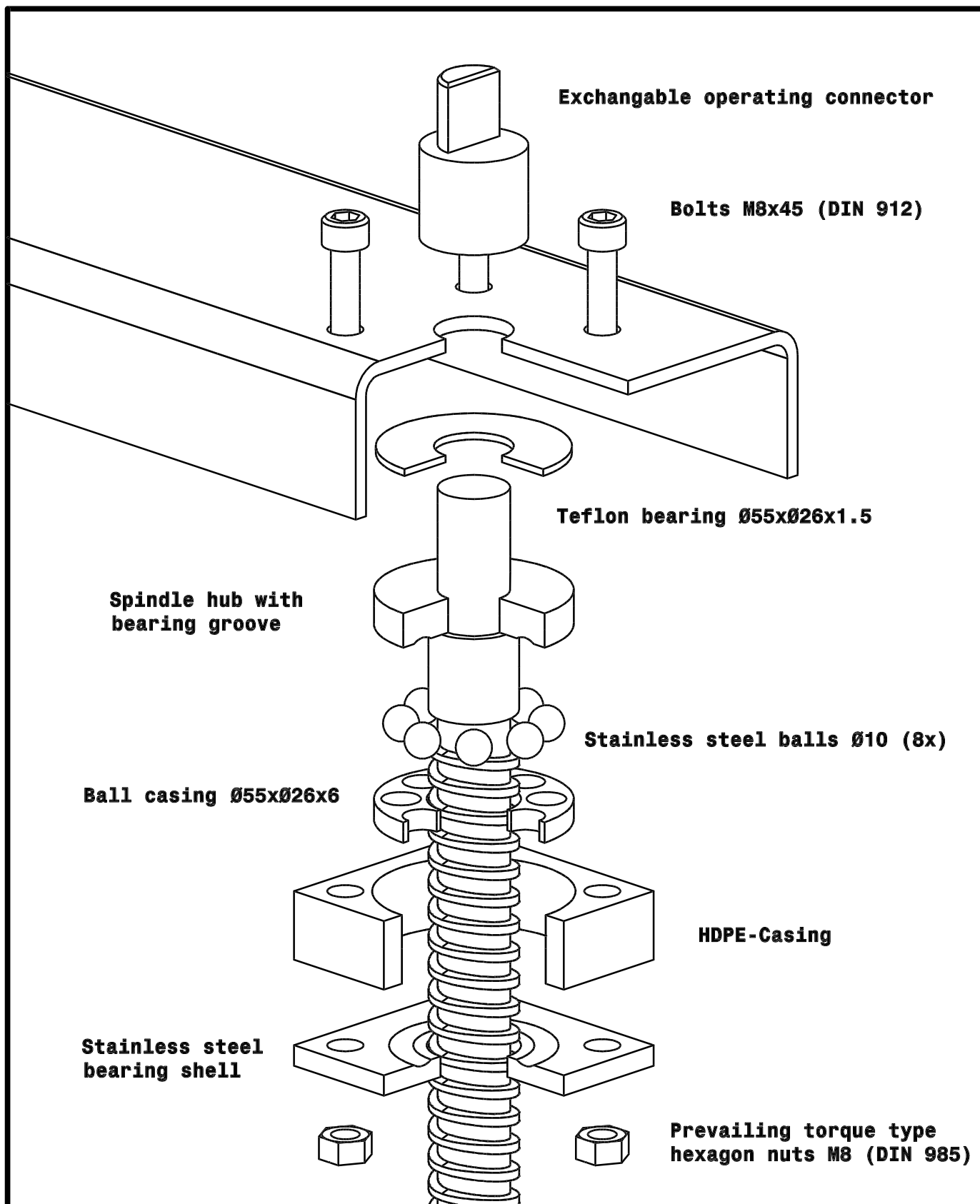

Synthesis BV - tel. +31 (0)321 380457
Koperweg 17 - 8251 KA Dronten

Casting Mould type IAP Ø400-Ø900

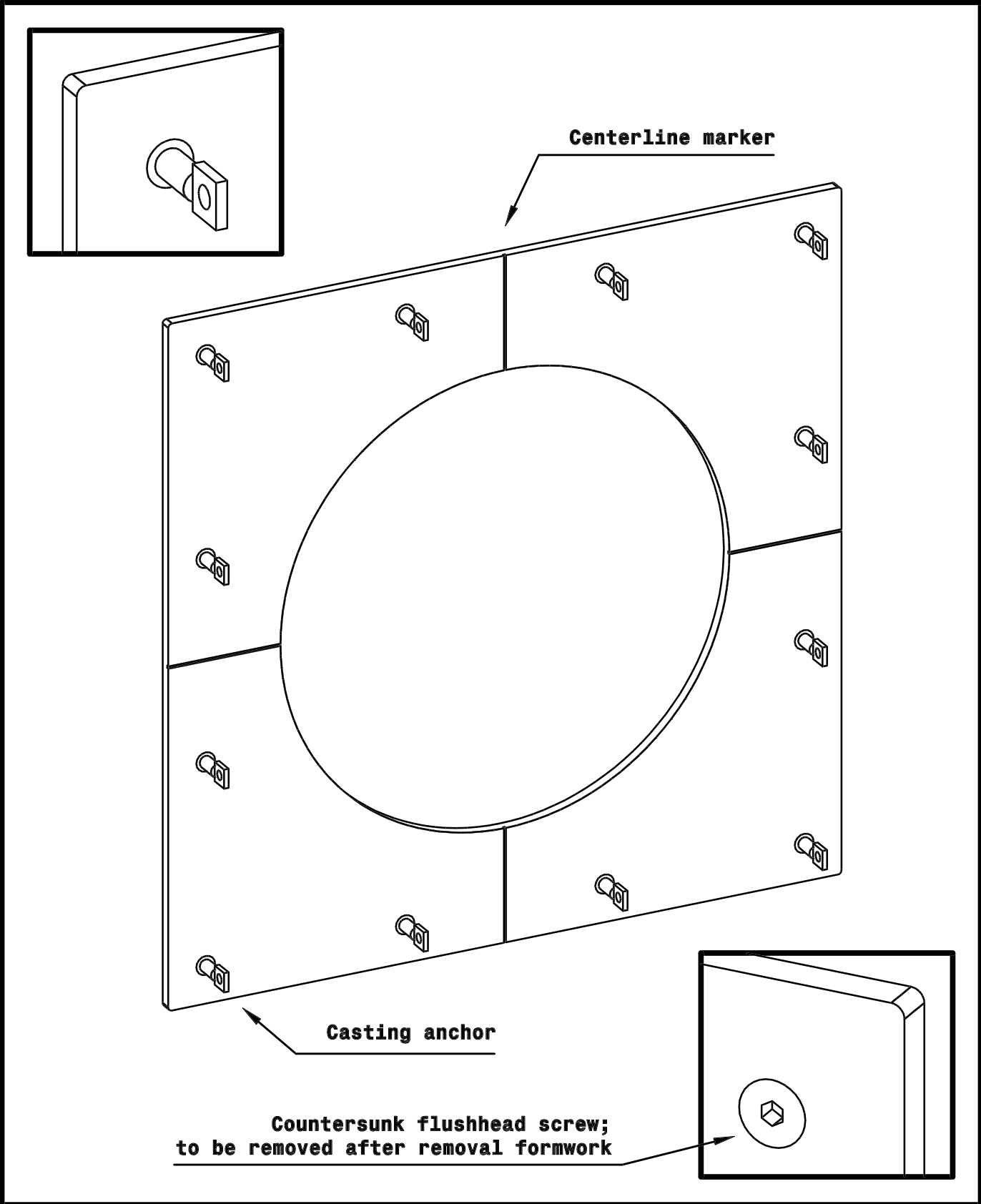

Synthesis BV - tel. +31 (0)321 380457
Koperweg 17 - 8251 KA Dronten