

Check valve NW 125-300 type P

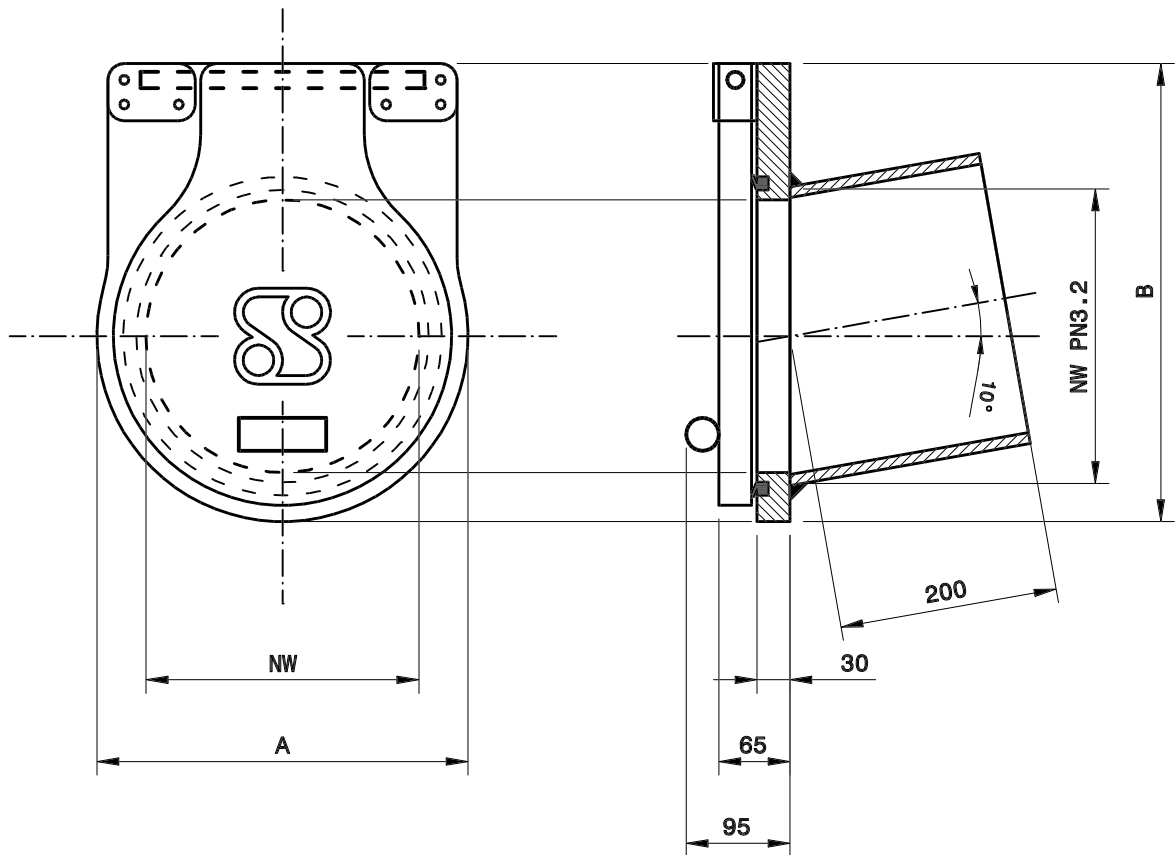

NW	A	B	weight
125	250	303	4 kg.
150	250	320	4 kg.
200	290	368	5 kg.
250	340	420	7 kg.
300	390	470	8 kg.

Material specification

Frame	- HDPE-300
Valve	- HMPE-500
Sealing	- EPDM
Valve axle	- Stainless AISI316
Bolts/nuts	- A4

Mounting	: spigot
Max. pressure	: 1 bar (14.5 psi)

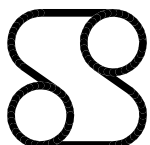
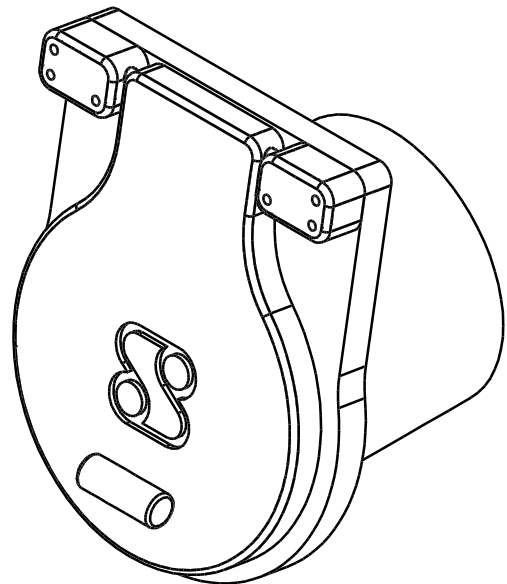

Synthesis BV - tel. +31 (0)321 380457
Koperweg 17 - 8251 KA Dronten

Check valve NW 400-600 type P

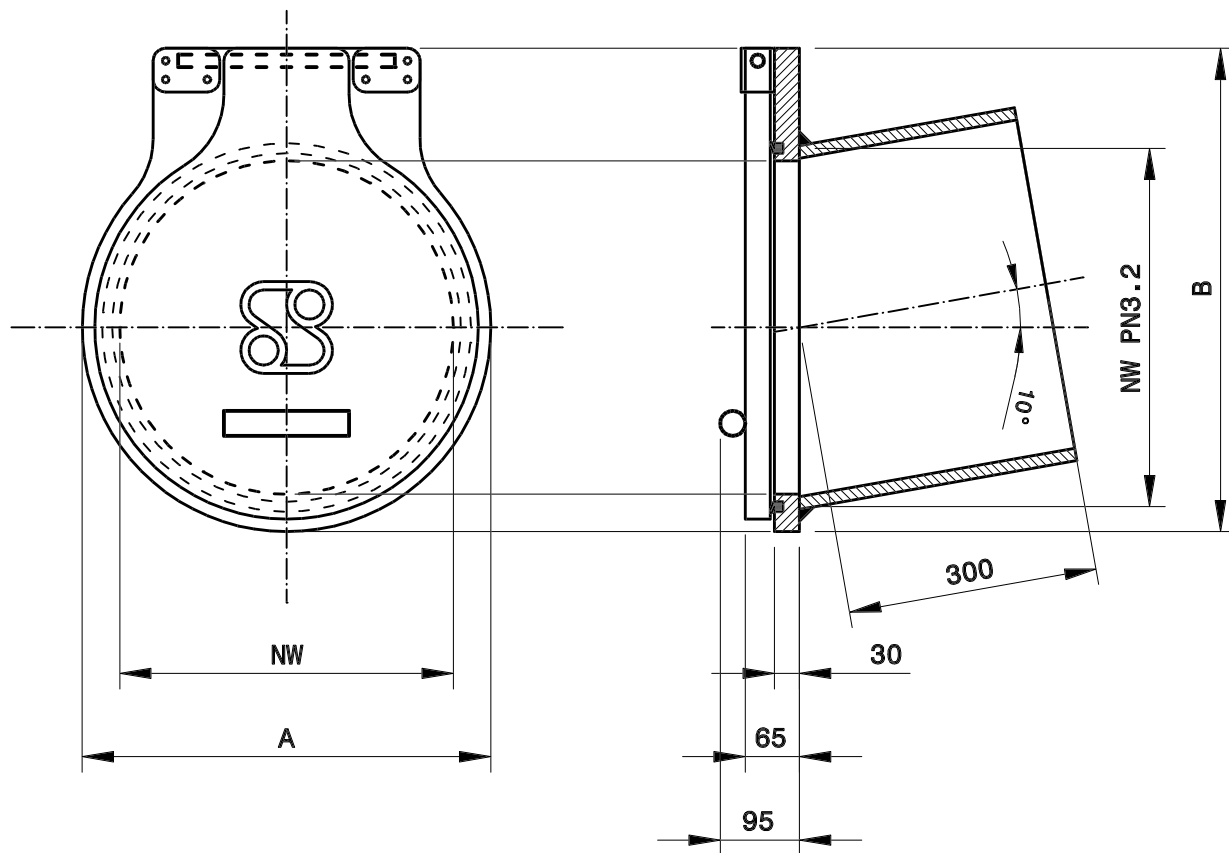

NW	A	B	weight
400	490	580	11 kg.
500	590	683	15 kg.
600	690	793	18 kg.

Material specification

Frame	- HDPE-300
Valve	- HMPE-500
Sealing	- EPDM
Valve axle	- Stainless AISI316
Bolts/nuts	- A4

Mounting	: spigot
Max. pressure	: 0.6 bar (8.7 psi)

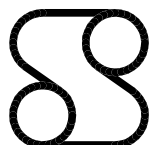
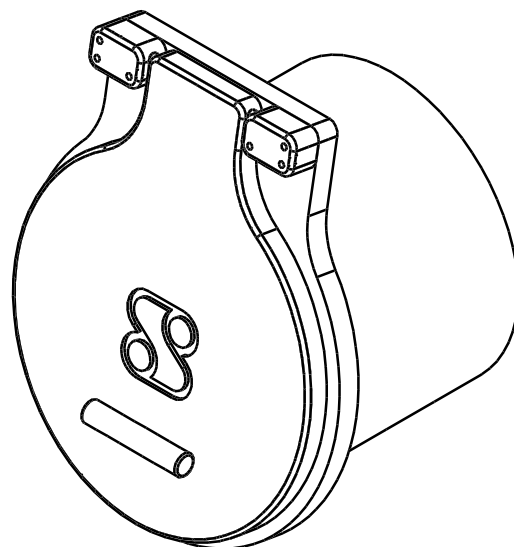

Synthesis BV - tel. +31 (0)321 380457
Koperweg 17 - 8251 KA Dronten